



POWER SKY (H.K.) LTD.

Digital transistors (built-in resistors)

DTA114TE/ DTA114TUA /DTA114TCA/ DTA114TKA/ DTA114TSA

TRANSISTOR (PNP)

FEATURES

- Built-in bias resistors enable the configuration of an inverter circuit without connecting external input resistors.
- The bias resistors consist of thin-film resistors with complete isolation to allow positive biasing of the input. They also have the advantage of almost completely eliminating parasitic effects.
- Only the on/off conditions need to be set for operation, marking device design easy.

●Equivalent circuit

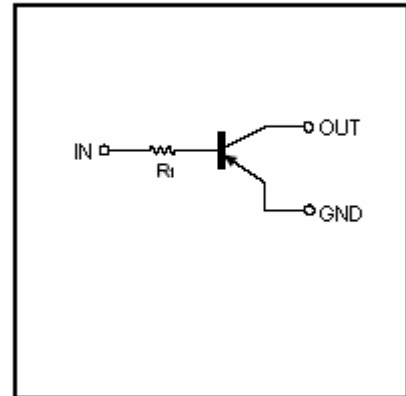

PIN CONNENCTIONS AND MARKING

<p>DTA114TE</p> <p>1.IN 2.GND 3.OUT</p> <p>SOT-523 Abbreviated symbol: 94</p>	<p>DTA114TUA</p> <p>1.IN 2.GND 3.OUT</p> <p>SOT-323 Abbreviated symbol: 94</p>
<p>DTA114TKA</p> <p>1.IN 2.GND 3.OUT</p> <p>SOT-23-3L Abbreviated symbol: 94</p>	<p>DTA114TCA</p> <p>1.IN 2.GND 3.OUT</p> <p>SOT-23 Abbreviated symbol: 94</p>
<p>DTA114TSA</p> <p>1.GND 2.OUT 3.IN</p> <p>TO-92S</p>	

MAXIMUM RATINGS* $T_A=25^{\circ}\text{C}$ unless otherwise noted

Symbol	Parameter	LIMITS(DTA114T□)					Units
		E	UA	KA	CA	SA	
V_{CBO}	Collector-Base Voltage	-50					V
V_{CEO}	Collector-Emitter Voltage	-50					V
V_{EBO}	Emitter-Base Voltage	-5					V
I_C	Collector Current -Continuous	-100					mA
P_C	Collector Dissipation	150	200			300	mW
T_J, T_{stg}	Junction and Storage Temperature	-55~+150					$^{\circ}\text{C}$

ELECTRICAL CHARACTERISTICS ($T_{amb}=25^{\circ}\text{C}$ unless otherwise specified)

Parameter	Symbol	Test conditions	MIN	TYP	MAX	UNIT
Collector-base breakdown voltage	$V_{(BR)CBO}$	$I_C=-50\mu\text{A}, I_E=0$	-50			V
Collector-emitter breakdown voltage	$V_{(BR)CEO}$	$I_C=-1\text{mA}, I_B=0$	-50			V
Emitter-base breakdown voltage	$V_{(BR)EBO}$	$I_E=-50\mu\text{A}, I_C=0$	-5			V
Collector cut-off current	I_{CBO}	$V_{CB}=-50\text{V}, I_E=0$			-0.5	μA
Emitter cut-off current	I_{EBO}	$V_{EB}=-4\text{V}, I_C=0$			-0.5	μA
DC current gain	h_{FE}	$V_{CE}=-5\text{V}, I_C=-1\text{mA}$	100	250	600	
Collector-emitter saturation voltage	$V_{CE(sat)}$	$I_C=-10\text{mA}, I_B=-1\text{mA}$			-0.3	V
Transition frequency	f_T	$V_{CE}=-10\text{V}, I_C=-5\text{mA}, f=100\text{MHz}$		250		MHz
Input resistor	R1		7	10	13	$k\Omega$

Typical Characteristics

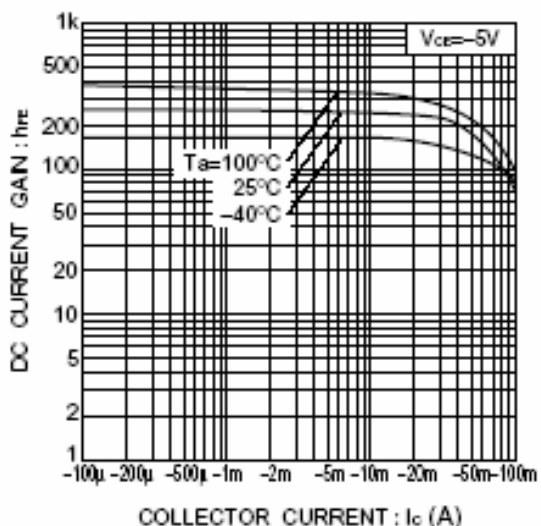

Fig.1 DC current gain vs. collector current

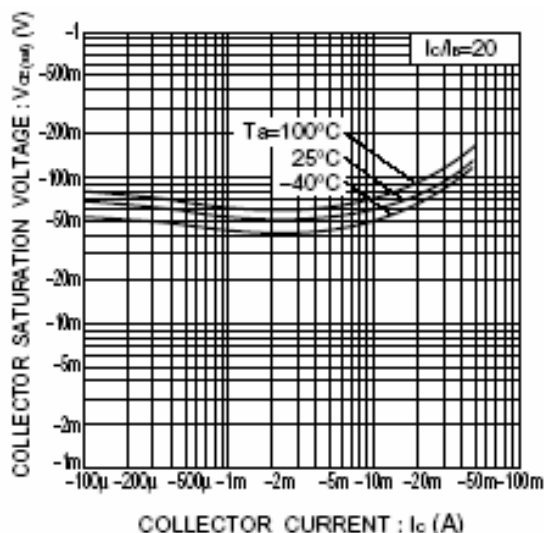

Fig.2 Collector-emitter saturation voltage vs. collector current